



Design Solutions™ 4_kitchen Decorative Panels



CONNECTED
WITH A CLICK

Decorative panels that will transform any kitchen

ARE YOU READY FOR SOMETHING NEW?

Discover innovative Design Solutions™ 4_kitchen decorative panels will reduce interior finishing costs and shorten redecoration time. Their base is MDF FSC® oard with low formaldehyde emission covered with high quality polymer film. In production, we use a reactive PUR adhesive, which makes the panels stand out for their resistance to moisture and increased temperature. The elements are combined on a 2G click, so you always have a perfect fit. Forget about the classic kitchen backsplash tiles! Time for modern solutions.

Design

IN LINE WITH LATEST TRENDS

In the Design Solutions™ 4_kitchen stock program, you will find carefully selected designs inspired by stone, concrete, metal and fabric patterns. We took care of the smallest details – each pattern is distinguished by its unique texture. We have also prepared a program available on individual order.

Design Solutions™ 4_kitchen decorative panels change the interior design, giving it a unique character. Thanks to the wide range of patterns, you can easily match the panels to the style of the worktop and kitchen furniture. We recommend using Design Solutions™ 4_kitchen decorative panels in places not exposed to direct water. We also offer panels with increased resistance to moisture on request.



Oxid grey
(standard)



Plaza stone
(standard)



Modernism Warmgrey
(standard)



Concrete black
(standard)



Marmur Carrera
(standard)



Vintage copper
(standard)

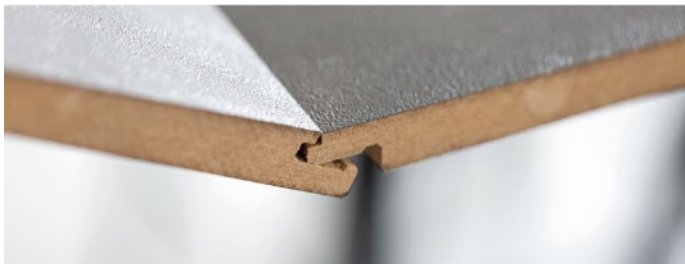

Technical data

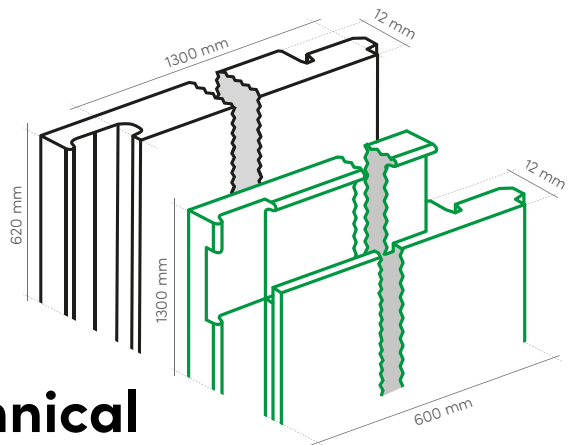

PRODUCT DETAILS

- ▶ 12 mm thick FSC® MDF board with reduced formaldehyde content
- ▶ panels for inter-cabinet strip
(click on vertical edges on 620 mm): 1300x620 mm
- ▶ panels for the niche for the absorber from the Design Solutions™ 4_interior product line available on request
(click on vertical and horizontal edges): 600x1300 mm
- ▶ surface finish:
high-quality polymer film and selected pattern
with a thickness of 0.15-0.4 mm
- ▶ edge finishing method:
horizontal - the manufacturer supplies panels with anti-moisture polyurethane protection (1300 mm each), **vertical** (after dimension 620 mm) - after cutting, we recommend finishing with silicone or generally available finishing strips used for ceramic tiles
- ▶ for finishing-sealing the edges between the worktop and the panels, we recommend using silicone strips
- ▶ mounting method: on a grate or on mounting adhesive
- ▶ the patented click 2G® connection technology licensed by VALINGE INNOVATIONS AB®
- ▶ extras: mounting adhesive, table top silicone strip in selected colors:



meets the requirements of DIN EN 16516



stain resistant



easy to clean



resistant to UV radiation



made of certified raw materials

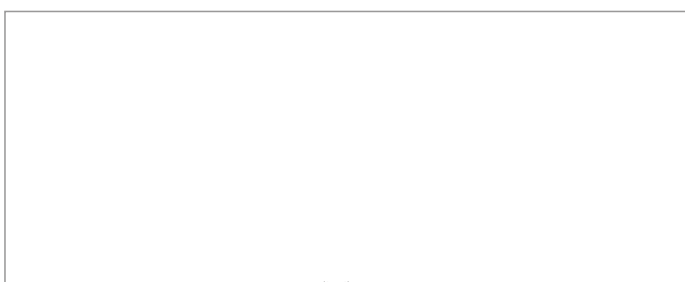

distributor

MELACO sp. z o.o.

Ciepielowska 9,
67-100 Nowa Sól, Poland

Headquarters: +48 68 38 79208
Sales: +48 68 38 72394

more info:

www.melaco.com.pl

melaco@melaco.com.pl

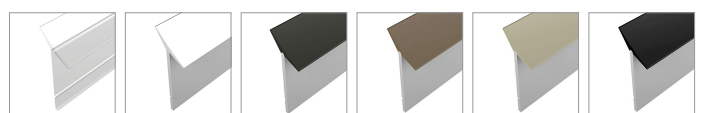

transparent

white

gray-brown

gray-beige

beige

black